



( ) Preliminary Specification  
(V) Final Specification

<b>Module</b>	18.5" Color TFT-LCD
<b>Model Name</b>	M185XW01 V0

<b>Customer</b>	<b>Date</b>
_____	_____
<b>Approved by</b>	
_____	_____
<p>Note: This Specification is subject to change without notice.</p>	

<b>Approved by</b>	<b>Date</b>
<u>Sean Chen</u>	<u>2008/11/18</u>
<b>Prepared by</b>	
<u>Chiyinwu</u>	<u>2008/11/18</u>
<p>Desktop Display Business Group / AU Optronics corporation</p>	

## Contents

<b>1.0 Handling Precautions .....</b>	<b>5</b>
<b>2.0 General Description .....</b>	<b>6</b>
2.1 Display Characteristics.....	6
2.2 Optical Characteristics .....	7
<b>3.0 Functional Block Diagram .....</b>	<b>11</b>
<b>4.0 Absolute Maximum Ratings .....</b>	<b>12</b>
4.1 TFT LCD Module.....	12
4.2 Backlight Unit .....	12
4.3 Absolute Ratings of Environment.....	12
<b>5.0 Electrical characteristics .....</b>	<b>13</b>
5.1 TFT LCD Module.....	13
5.1.1 Power Specification .....	13
5.1.2 Signal Electrical Characteristics .....	14
5.2 Backlight Unit .....	15
<b>6.0 Signal Characteristic.....</b>	<b>17</b>
6.1 Pixel Format Image .....	17
6.2 The input data format.....	18
6.3 Signal Description .....	19
6.4 Timing Characteristics.....	21
6.5 Timing diagram .....	22
6.6 Power ON/OFF Sequence .....	23
<b>7.0 Connector &amp; Pin Assignment.....</b>	<b>24</b>
7.1 TFT LCD Module.....	24
7.1.1 Pin Assignment .....	24
7.2 Backlight Unit .....	25
7.2.1 Signal for Lamp connector .....	25
<b>8.0 Reliability Test.....</b>	<b>26</b>
<b>9.0 Shipping Label .....</b>	<b>27</b>
<b>10.0 Mechanical Characteristics .....</b>	<b>28</b>

## Record of Revision

Version and Date	Page	Old description	New Description	Remark																																																																
0.1 2008/03/10	All	First Edition for Customer	N/A																																																																	
0.2 2008/06/02	All	old format	new format																																																																	
	5	2.1 Display Characteristics 1. No screen diagonal description 2. weight 1900(max) TDB 3. No temperature range	2.1 Display Characteristics 1. add screen diagonal : 470.1 mm (18.51") 2. weight 2000 (max) 3. add temperature range 甲、 operating 0~+50 [°C] 乙、 storage (shipping) -20 to +60 [°C]																																																																	
	6	View angel <table border="1" data-bbox="300 952 774 1187"> <thead> <tr> <th>Item</th> <th>Unit</th> <th>Conditions</th> <th>Min.</th> <th>Typ.</th> <th>Max.</th> <th>Note</th> </tr> </thead> <tbody> <tr> <td rowspan="8">Viewing Angle</td> <td rowspan="8">[degree]</td> <td>Horizontal (Right)</td> <td>70</td> <td>95</td> <td>-</td> <td rowspan="8">1</td> </tr> <tr> <td>CR = 10 (Left)</td> <td>70</td> <td>95</td> <td>-</td> </tr> <tr> <td>Vertical (Up)</td> <td>70</td> <td>95</td> <td>-</td> </tr> <tr> <td>CR = 10 (Down)</td> <td>70</td> <td>95</td> <td>-</td> </tr> <tr> <td>Horizontal (Right)</td> <td>75</td> <td>95</td> <td>-</td> </tr> <tr> <td>CR = 5 (Left)</td> <td>75</td> <td>95</td> <td>-</td> </tr> <tr> <td>Vertical (Right)</td> <td>75</td> <td>95</td> <td>-</td> </tr> <tr> <td>CR = 5 (Left)</td> <td>75</td> <td>95</td> <td>-</td> </tr> </tbody> </table>	Item	Unit	Conditions	Min.	Typ.	Max.	Note	Viewing Angle	[degree]	Horizontal (Right)	70	95	-	1	CR = 10 (Left)	70	95	-	Vertical (Up)	70	95	-	CR = 10 (Down)	70	95	-	Horizontal (Right)	75	95	-	CR = 5 (Left)	75	95	-	Vertical (Right)	75	95	-	CR = 5 (Left)	75	95	-	<table border="1" data-bbox="782 907 1436 1131"> <thead> <tr> <th>Item</th> <th>Unit</th> <th>Conditions</th> <th>Min.</th> <th>Typ.</th> <th>Max.</th> <th>Note</th> </tr> </thead> <tbody> <tr> <td rowspan="4">Viewing Angle</td> <td rowspan="4">[degree]</td> <td>Horizontal (Right)</td> <td rowspan="2">150</td> <td rowspan="2">170</td> <td>-</td> <td rowspan="4">2</td> </tr> <tr> <td>CR = 10 (Left)</td> <td>-</td> </tr> <tr> <td>Vertical (Up)</td> <td rowspan="2">140</td> <td rowspan="2">160</td> <td>-</td> </tr> <tr> <td>CR = 10 (Down)</td> <td>-</td> </tr> </tbody> </table>	Item	Unit	Conditions	Min.	Typ.	Max.	Note	Viewing Angle	[degree]	Horizontal (Right)	150	170	-	2	CR = 10 (Left)	-	Vertical (Up)	140	160	-	CR = 10 (Down)	-	
Item	Unit	Conditions	Min.	Typ.	Max.	Note																																																														
Viewing Angle	[degree]	Horizontal (Right)	70	95	-	1																																																														
		CR = 10 (Left)	70	95	-																																																															
		Vertical (Up)	70	95	-																																																															
		CR = 10 (Down)	70	95	-																																																															
		Horizontal (Right)	75	95	-																																																															
		CR = 5 (Left)	75	95	-																																																															
		Vertical (Right)	75	95	-																																																															
		CR = 5 (Left)	75	95	-																																																															
Item	Unit	Conditions	Min.	Typ.	Max.	Note																																																														
Viewing Angle	[degree]	Horizontal (Right)	150	170	-	2																																																														
		CR = 10 (Left)			-																																																															
		Vertical (Up)	140	160	-																																																															
		CR = 10 (Down)			-																																																															
10	1. I/F PCB interface  FI-XB30SSRL-HF16 (JAE) / MSCKT2407P30B (信盛)  2. Lamp connector  CVILUX CP0502SL090 / YEON HO 35001HS-02L  Mating Type: 35001WR-02LP	1. I/F PCB Interface:  FI-XB30SSRL-HF16(JAE)/MSCKT2407P30HB(信盛)  2. Lamp connector  Deleted																																																																		
14	5.1.2 Signal Electrical Characteristics <table border="1" data-bbox="300 1624 774 1736"> <thead> <tr> <th>Parameter</th> <th>Min</th> <th>Typ</th> <th>Max</th> <th>Units</th> <th>Condition</th> </tr> </thead> <tbody> <tr> <td>Differential Input High Threshold</td> <td>-</td> <td>-</td> <td>100</td> <td>[mV]</td> <td>V<sub>CM</sub> = 1.2V Note</td> </tr> <tr> <td>Differential Input Low Threshold</td> <td>-100</td> <td>-</td> <td>-</td> <td>[mV]</td> <td>V<sub>CM</sub> = 1.2V Note</td> </tr> <tr> <td>Differential Input Common Mode Voltage</td> <td>1</td> <td>1.2</td> <td>1.5</td> <td>[V]</td> <td>V<sub>TH/VTL</sub> = ±100mV Note</td> </tr> </tbody> </table>	Parameter	Min	Typ	Max	Units	Condition	Differential Input High Threshold	-	-	100	[mV]	V <sub>CM</sub> = 1.2V Note	Differential Input Low Threshold	-100	-	-	[mV]	V <sub>CM</sub> = 1.2V Note	Differential Input Common Mode Voltage	1	1.2	1.5	[V]	V <sub>TH/VTL</sub> = ±100mV Note	<table border="1" data-bbox="782 1579 1436 1758"> <thead> <tr> <th>Parameter</th> <th>Min</th> <th>Typ</th> <th>Max</th> <th>Units</th> <th>Condition</th> </tr> </thead> <tbody> <tr> <td>Differential Input High Threshold</td> <td>-</td> <td>50</td> <td>100</td> <td>[mV]</td> <td>V<sub>CM</sub> = 1.2V Note 1</td> </tr> <tr> <td>Differential Input Low Threshold</td> <td>-100</td> <td>-50</td> <td>-</td> <td>[mV]</td> <td>V<sub>CM</sub> = 1.2V Note 1</td> </tr> <tr> <td>Differential Input Common Mode Voltage</td> <td>1</td> <td>1.2</td> <td>1.4</td> <td>[V]</td> <td>V<sub>TH-VTL</sub> = 200mV (max) Note 1</td> </tr> </tbody> </table>	Parameter	Min	Typ	Max	Units	Condition	Differential Input High Threshold	-	50	100	[mV]	V <sub>CM</sub> = 1.2V Note 1	Differential Input Low Threshold	-100	-50	-	[mV]	V <sub>CM</sub> = 1.2V Note 1	Differential Input Common Mode Voltage	1	1.2	1.4	[V]	V <sub>TH-VTL</sub> = 200mV (max) Note 1																		
Parameter	Min	Typ	Max	Units	Condition																																																															
Differential Input High Threshold	-	-	100	[mV]	V <sub>CM</sub> = 1.2V Note																																																															
Differential Input Low Threshold	-100	-	-	[mV]	V <sub>CM</sub> = 1.2V Note																																																															
Differential Input Common Mode Voltage	1	1.2	1.5	[V]	V <sub>TH/VTL</sub> = ±100mV Note																																																															
Parameter	Min	Typ	Max	Units	Condition																																																															
Differential Input High Threshold	-	50	100	[mV]	V <sub>CM</sub> = 1.2V Note 1																																																															
Differential Input Low Threshold	-100	-50	-	[mV]	V <sub>CM</sub> = 1.2V Note 1																																																															
Differential Input Common Mode Voltage	1	1.2	1.4	[V]	V <sub>TH-VTL</sub> = 200mV (max) Note 1																																																															
15	5.2 BL unit (1) <table border="1" data-bbox="300 1848 774 1948"> <thead> <tr> <th>Parameter</th> <th>Min.</th> <th>Typ.</th> <th>Max.</th> <th>Unit</th> <th>Condition</th> </tr> </thead> <tbody> <tr> <td>CCFL's operation voltage (V<sub>OP</sub>)</td> <td>100</td> <td>-</td> <td>-</td> <td>[V(rms)]</td> <td>Note 1</td> </tr> <tr> <td>CCFL's operation voltage (V<sub>OP</sub>) (Tan 2θ)</td> <td>120</td> <td>-</td> <td>-</td> <td>[V(rms)]</td> <td>Note 1</td> </tr> <tr> <td>CCFL's operation voltage (V<sub>OP</sub>) (Tan 2θ)</td> <td>-</td> <td>70</td> <td>90</td> <td>[V(rms)]</td> <td>Note 1</td> </tr> <tr> <td>CCFL's operation voltage (V<sub>OP</sub>) (Tan 2θ)</td> <td>-</td> <td>10</td> <td>1.10</td> <td>[Watt]</td> <td>Note 1</td> </tr> </tbody> </table> (2) Note 8: The CCFL can work normally if the PWM Dimming ratio range is from 20% to 100% and the lamp current is 7.5mA	Parameter	Min.	Typ.	Max.	Unit	Condition	CCFL's operation voltage (V <sub>OP</sub> )	100	-	-	[V(rms)]	Note 1	CCFL's operation voltage (V <sub>OP</sub> ) (Tan 2θ)	120	-	-	[V(rms)]	Note 1	CCFL's operation voltage (V <sub>OP</sub> ) (Tan 2θ)	-	70	90	[V(rms)]	Note 1	CCFL's operation voltage (V <sub>OP</sub> ) (Tan 2θ)	-	10	1.10	[Watt]	Note 1	(1) <table border="1" data-bbox="782 1803 1436 1982"> <thead> <tr> <th>Parameter</th> <th>Min.</th> <th>Typ.</th> <th>Max.</th> <th>Unit</th> <th>Note</th> </tr> </thead> <tbody> <tr> <td>CCFL Ignition Voltage (V<sub>IG</sub>) (Tan 2θ)</td> <td>1650</td> <td>-</td> <td>-</td> <td>[V(rms)]</td> <td>3</td> </tr> <tr> <td>CCFL Ignition Voltage (V<sub>IG</sub>) (Tan 2θ)</td> <td>1250</td> <td>-</td> <td>-</td> <td>[V(rms)]</td> <td>3</td> </tr> <tr> <td>CCFL Operation Voltage (V<sub>OP</sub>)</td> <td>-</td> <td>700 @ 7.5mA</td> <td>800</td> <td>[V(rms)]</td> <td>4</td> </tr> <tr> <td>CCFL Power Consumption (P<sub>CCFL</sub>)</td> <td>-</td> <td>11</td> <td>12.1</td> <td>[Watt]</td> <td>4</td> </tr> </tbody> </table> Note 2: CCFL standard current is measured by cosine mode inverter at 25±2°C  (2) Deleted Notes 8	Parameter	Min.	Typ.	Max.	Unit	Note	CCFL Ignition Voltage (V <sub>IG</sub> ) (Tan 2θ)	1650	-	-	[V(rms)]	3	CCFL Ignition Voltage (V <sub>IG</sub> ) (Tan 2θ)	1250	-	-	[V(rms)]	3	CCFL Operation Voltage (V <sub>OP</sub> )	-	700 @ 7.5mA	800	[V(rms)]	4	CCFL Power Consumption (P <sub>CCFL</sub> )	-	11	12.1	[Watt]	4						
Parameter	Min.	Typ.	Max.	Unit	Condition																																																															
CCFL's operation voltage (V <sub>OP</sub> )	100	-	-	[V(rms)]	Note 1																																																															
CCFL's operation voltage (V <sub>OP</sub> ) (Tan 2θ)	120	-	-	[V(rms)]	Note 1																																																															
CCFL's operation voltage (V <sub>OP</sub> ) (Tan 2θ)	-	70	90	[V(rms)]	Note 1																																																															
CCFL's operation voltage (V <sub>OP</sub> ) (Tan 2θ)	-	10	1.10	[Watt]	Note 1																																																															
Parameter	Min.	Typ.	Max.	Unit	Note																																																															
CCFL Ignition Voltage (V <sub>IG</sub> ) (Tan 2θ)	1650	-	-	[V(rms)]	3																																																															
CCFL Ignition Voltage (V <sub>IG</sub> ) (Tan 2θ)	1250	-	-	[V(rms)]	3																																																															
CCFL Operation Voltage (V <sub>OP</sub> )	-	700 @ 7.5mA	800	[V(rms)]	4																																																															
CCFL Power Consumption (P <sub>CCFL</sub> )	-	11	12.1	[Watt]	4																																																															

	21	6.4.1 Timing Characteristics	<table border="1"> <thead> <tr> <th>Signal</th> <th>Item</th> <th>Symbol</th> <th>Min</th> <th>Typ</th> <th>Max</th> <th>Unit</th> </tr> </thead> <tbody> <tr> <td rowspan="3">H-section</td> <td>Period</td> <td>Th</td> <td>1480</td> <td>1500</td> <td>2047</td> <td>Tclk</td> </tr> <tr> <td>Active</td> <td>Tdup(h)</td> <td>1365</td> <td>1365</td> <td>1365</td> <td>Tclk</td> </tr> <tr> <td>Blanking</td> <td>Tblk(h)</td> <td>134</td> <td>240</td> <td>621</td> <td>Tclk</td> </tr> </tbody> </table> <p>Note2 : Clock Frequency 90MHz(Max) = 14650(H)*847(V)*75Hz</p>	Signal	Item	Symbol	Min	Typ	Max	Unit	H-section	Period	Th	1480	1500	2047	Tclk	Active	Tdup(h)	1365	1365	1365	Tclk	Blanking	Tblk(h)	134	240	621	Tclk	
Signal	Item	Symbol	Min	Typ	Max	Unit																								
H-section	Period	Th	1480	1500	2047	Tclk																								
	Active	Tdup(h)	1365	1365	1365	Tclk																								
	Blanking	Tblk(h)	134	240	621	Tclk																								
	24	7.1 TFT LCD Module	<table border="1"> <thead> <tr> <th>Connector Name / Designation</th> <th>Interface Connector / Interface card</th> </tr> </thead> <tbody> <tr> <td>Type Part Number</td> <td>FI-XB30SSRL-HF16(JAE)/MSCKT2407P30HB(STM)</td> </tr> </tbody> </table>	Connector Name / Designation	Interface Connector / Interface card	Type Part Number	FI-XB30SSRL-HF16(JAE)/MSCKT2407P30HB(STM)																							
Connector Name / Designation	Interface Connector / Interface card																													
Type Part Number	FI-XB30SSRL-HF16(JAE)/MSCKT2407P30HB(STM)																													
	25	7.2 Backlight Unit	<table border="1"> <thead> <tr> <th>Connector Name / Designation</th> <th>Lamp Connector / Backlight lamp</th> </tr> </thead> <tbody> <tr> <td>Manufacturer</td> <td>YEON HO</td> </tr> <tr> <td>Type Part Number</td> <td>35001HS-02L</td> </tr> <tr> <td>Mating Type Part Number</td> <td>35001WR-02LP</td> </tr> </tbody> </table>	Connector Name / Designation	Lamp Connector / Backlight lamp	Manufacturer	YEON HO	Type Part Number	35001HS-02L	Mating Type Part Number	35001WR-02LP																			
Connector Name / Designation	Lamp Connector / Backlight lamp																													
Manufacturer	YEON HO																													
Type Part Number	35001HS-02L																													
Mating Type Part Number	35001WR-02LP																													
	27	9.0 Shipping Label																												
	28,29	2D drawing –PCBA	2D drawing –change PCBA size																											
0.3 2008/6/13	21	6.4.1 Timing Characteristics	<table border="1"> <thead> <tr> <th>Signal</th> <th>Item</th> <th>Symbol</th> <th>Min</th> <th>Typ</th> <th>Max</th> <th>Unit</th> </tr> </thead> <tbody> <tr> <td rowspan="3">H-section</td> <td>Period</td> <td>Th</td> <td>1416</td> <td>1416</td> <td>2047</td> <td>Tclk</td> </tr> <tr> <td>Active</td> <td>Tdup(h)</td> <td>1366</td> <td>1366</td> <td>1366</td> <td>Tclk</td> </tr> <tr> <td>Blanking</td> <td>Tblk(h)</td> <td>50</td> <td>240</td> <td>681</td> <td>Tclk</td> </tr> </tbody> </table> <p>Note2 : Clock Frequency 90MHz(Max) = 1416(H)*847(V)*75Hz</p>	Signal	Item	Symbol	Min	Typ	Max	Unit	H-section	Period	Th	1416	1416	2047	Tclk	Active	Tdup(h)	1366	1366	1366	Tclk	Blanking	Tblk(h)	50	240	681	Tclk	
Signal	Item	Symbol	Min	Typ	Max	Unit																								
H-section	Period	Th	1416	1416	2047	Tclk																								
	Active	Tdup(h)	1366	1366	1366	Tclk																								
	Blanking	Tblk(h)	50	240	681	Tclk																								
1.0 2008/6/13		Preliminary	Final																											
1.1 2008/7/30	13	5.1.1 Power Specification	<table border="1"> <thead> <tr> <th>Symbol</th> <th>Parameter</th> <th>Min</th> <th>Typ</th> <th>Max</th> <th>Unit</th> <th>Conditions</th> </tr> </thead> <tbody> <tr> <td>IDD</td> <td>Input Current</td> <td>-</td> <td>1.2</td> <td>1.5</td> <td>[A]</td> <td>VDD= 5.0V, All Back Pattern At 60Hz.</td> </tr> <tr> <td>POD</td> <td>VDD Power/VDD Power</td> <td>-</td> <td>6</td> <td>8.25</td> <td>[Watt]</td> <td>VDD= 5.0V, All Back Pattern At 60Hz.</td> </tr> </tbody> </table>	Symbol	Parameter	Min	Typ	Max	Unit	Conditions	IDD	Input Current	-	1.2	1.5	[A]	VDD= 5.0V, All Back Pattern At 60Hz.	POD	VDD Power/VDD Power	-	6	8.25	[Watt]	VDD= 5.0V, All Back Pattern At 60Hz.						
Symbol	Parameter	Min	Typ	Max	Unit	Conditions																								
IDD	Input Current	-	1.2	1.5	[A]	VDD= 5.0V, All Back Pattern At 60Hz.																								
POD	VDD Power/VDD Power	-	6	8.25	[Watt]	VDD= 5.0V, All Back Pattern At 60Hz.																								
	18	No Notes 3	Add Note3: This model LVDS format is NS format.																											
	27	Dell barcode number with 20 digits	Correct Dell barcode number from 20 to 23 digits																											
	28	N/A	Fine tune 2D drawing –tolerance and general tolerance table and add Note 4																											
	20,29	Barcode label in center location and shielding cover with text	Change barcode label location and remove text from shielding cover																											
1.2 2008/11/18	28,29	2D drawing show Model name M185XW01 V1	Correct 2D drawing Model name from M185XW01 V1 to M185XW01 V0																											
1.2 2009/6/4	18		A 6.2 The input data format → Remove NS format 6bit diagram → Remove JEIDA format definition																											

## 1.0 Handling Precautions

- 1) Since front polarizer is easily damaged, pay attention not to scratch it.
- 2) Be sure to turn off power supply when inserting or disconnecting from input connector.
- 3) Wipe off water drop immediately. Long contact with water may cause discoloration or spots.
- 4) When the panel surface is soiled, wipe it with absorbent cotton or other soft cloth.
- 5) Since the panel is made of glass, it may break or crack if dropped or bumped on hard surface.
- 6) Since CMOS LSI is used in this module, take care of static electricity and insure human earth when handling.
- 7) Do not open or modify the Module Assembly.
- 8) Do not press the reflector sheet at the back of the module to any directions.
- 9) In case if a Module has to be put back into the packing container slot after once it was taken out from the container, do not press the center of the CCFL reflector edge. Instead, press at the far ends of the CCFL Reflector edge softly. Otherwise the TFT Module may be damaged.
- 10) At the insertion or removal of the Signal Interface Connector, be sure not to rotate nor tilt the Interface Connector of the TFT Module.
- 11) After installation of the TFT Module into an enclosure, do not twist nor bend the TFT Module even momentary. At designing the enclosure, it should be taken into consideration that no bending/twisting forces are applied to the TFT Module from outside. Otherwise the TFT Module may be damaged.
- 12) Cold cathode fluorescent lamp in LCD contains a small amount of mercury. Please follow local ordinances or regulations for disposal.
- 13) Small amount of materials having no flammability grade is used in the LCD module. The LCD module should be supplied by power complied with requirements of Limited Power Source (IEC60950 or UL1950), or be applied exemption.
- 14) The LCD module is designed so that the CCFL in it is supplied by Limited Current Circuit (IEC60950 or UL1950). Do not connect the CCFL in Hazardous Voltage Circuit.

## 2.0 General Description

This specification applies to the 18.5 inch-wide Color a-Si TFT-LCD Module M185XW01. The display supports the WXGA - 1366(H) x 768(V) screen format and 16.7M colors (RGB 6-bits + Hi-FRC data). All input signals are 1-channel LVDS interface and this module doesn't contain an inverter board for backlight.

## 2.1 Display Characteristics

The following items are characteristics summary on the table under 25 condition:

ITEMS	Unit	SPECIFICATIONS
Screen Diagonal	[mm]	470.1(18.51")
Active Area	[mm]	409.8 (H) x 230.4 (V)
Pixels H x V		1366(x3) x 768
Pixel Pitch	[um]	300 (per one triad) × 300
Pixel Arrangement		R.G.B. Vertical Stripe
Display Mode		TN Mode, Normally White
White Luminance ( Center )	[cd/m <sup>2</sup> ]	300 cd/m <sup>2</sup> (@ 7.5mA (Typ.))
Contrast Ratio		1000 (Typ.)
Optical Response Time	[msec]	5ms (Typ., on/off)
Nominal Input Voltage VDD	[Volt]	+5.0 V (Typ)
Power Consumption (VDD line + CCFL line)	[Watt]	17 W (Typ.) (without inverter, all black pattern)
Weight	[Grams]	2000 (Max)
Physical Size	[mm]	430.37 (W) x 254.6 (H) Typ. x 16.5 (D) Max
Electrical Interface		One channel LVDS
Support Color		16.7M colors (RGB 6-bit + Hi_FRC )
Surface Treatment		Anti-Glare, 3H
Temperature Range		
Operating	[°C]	0 to +50
Storage (Shipping)	[°C]	-20 to +60
RoHS Compliance		RoHS Compliance

## 2.2 Optical Characteristics

The optical characteristics are measured under stable conditions at 25 °C :

Item	Unit	Conditions	Min.	Typ.	Max.	Note
Viewing Angle	[degree]	Horizontal (Right) CR = 10 (Left)	150	170	-	<b>2</b>
		Vertical (Up) CR = 10 (Down)	140	160	-	
Contrast ratio		Normal Direction	600	1000	-	<b>3</b>
Response Time	[msec]	Raising Time (T <sub>RR</sub> )	-	3.6	5.7	<b>4</b>
		Falling Time (T <sub>RF</sub> )	-	1.4	2.3	
		Raising + Falling	-	5	8	
Color / Chromaticity Coordinates (CIE)		Red x	0.618	0.648	0.678	<b>5</b>
		Red y	0.309	0.339	0.369	
		Green x	0.262	0.292	0.322	
		Green y	0.573	0.603	0.633	
		Blue x	0.113	0.143	0.173	
		Blue y	0.040	0.070	0.100	
Color Coordinates (CIE) White		White x	0.283	0.313	0.343	<b>5</b>
		White y	0.299	0.329	0.359	
Central Luminance	[cd/m <sup>2</sup> ]		240	300	-	<b>6</b>
Luminance Uniformity	[%]		75	80	-	<b>7</b>
Crosstalk (in 60Hz)	[%]				1.5	<b>8</b>
Flicker	dB				-20	<b>9</b>

**Note 1:** Measurement method

The LCD module should be stabilized at given temperature for 30 minutes to avoid abrupt temperature change during measuring (at surface 35 °C). In order to stabilize the luminance, the measurement should be executed after lighting Backlight for 30 minutes in a stable, windless and dark room.

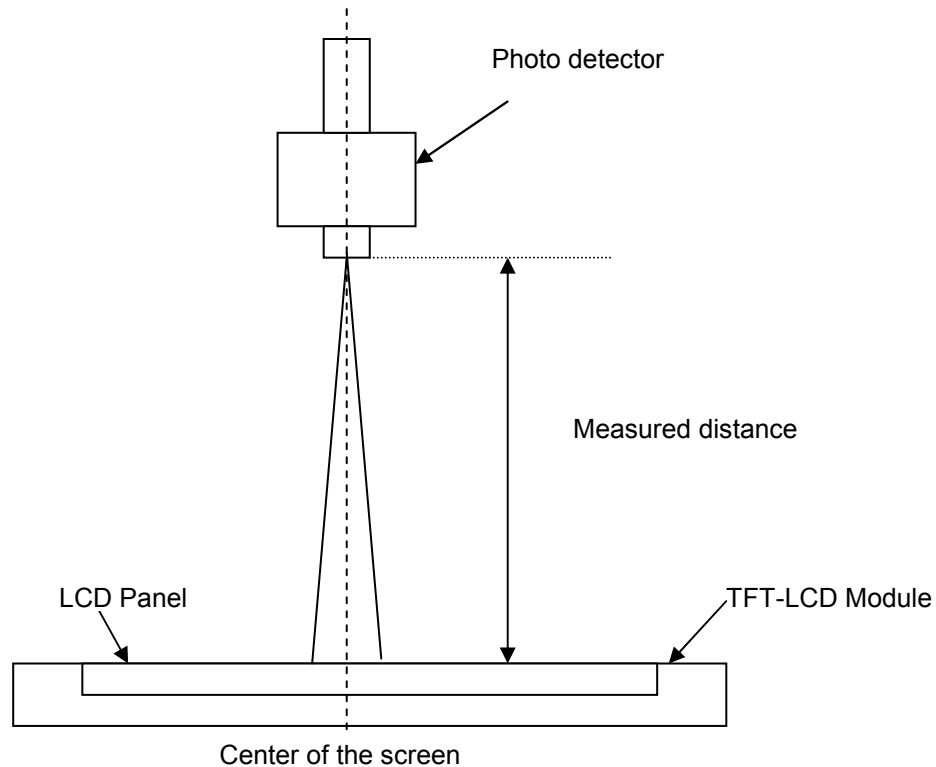

**Note 2:** Definition of viewing angle measured by ELDIM (EZContrast 88)

Viewing angle is the measurement of contrast ratio  $\geq 10$ , at the screen center, over a 180° horizontal and 180° vertical range (off-normal viewing angles). The 180° viewing angle range is broken down as follows; 90° ( $\theta$ ) horizontal left and right and 90° ( $\phi$ ) vertical, high (up) and low (down). The measurement direction is typically perpendicular to the display surface with the screen rotated about its center to develop the desired measurement viewing angle.

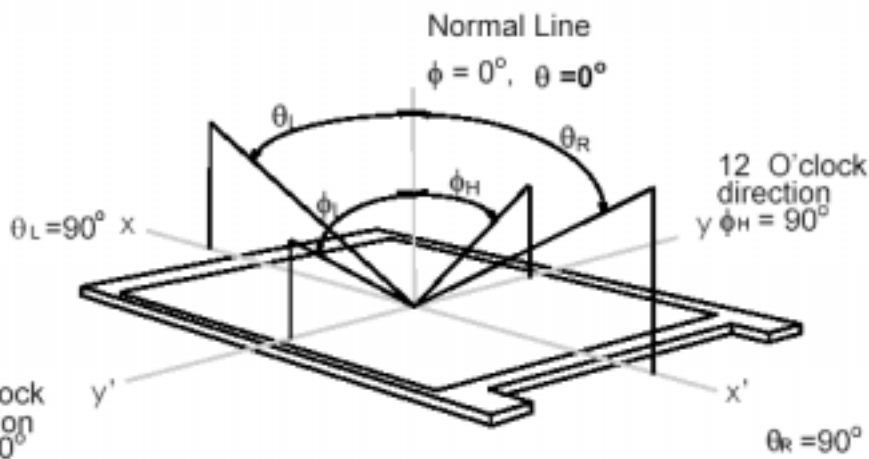



**Note 3:** Contrast ratio is measured by TOPCON SR-3

**Note 4:** Definition of Response time measured by Westar TRD-100A

The output signals of photo detector are measured when the input signals are changed from “Full Black” to “Full White” (rising time,  $Tr_R$ ), and from “Full White” to “Full Black” (falling time,  $Tf_F$ ), respectively. The response time is interval between the 10% and 90% (1 frame at 60 Hz) of amplitudes.

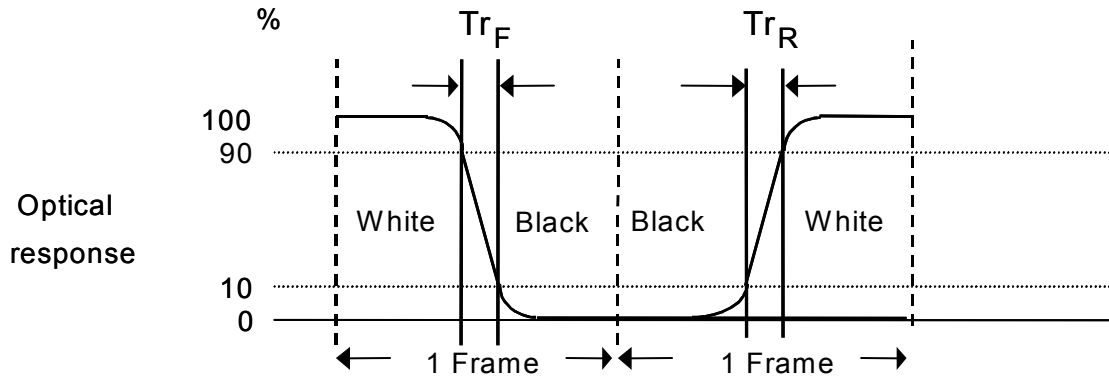

$Tr_R + Tf_F = 5 \text{ msec (typ.)}$ .

**Note 5:** Color chromaticity and coordinates (CIE) is measured by TOPCON SR-3

**Note 6:** Central luminance is measured by TOPCON SR-3

**Note 7:** Luminance uniformity of these 9 points is defined as below and measured by TOPCON SR-3

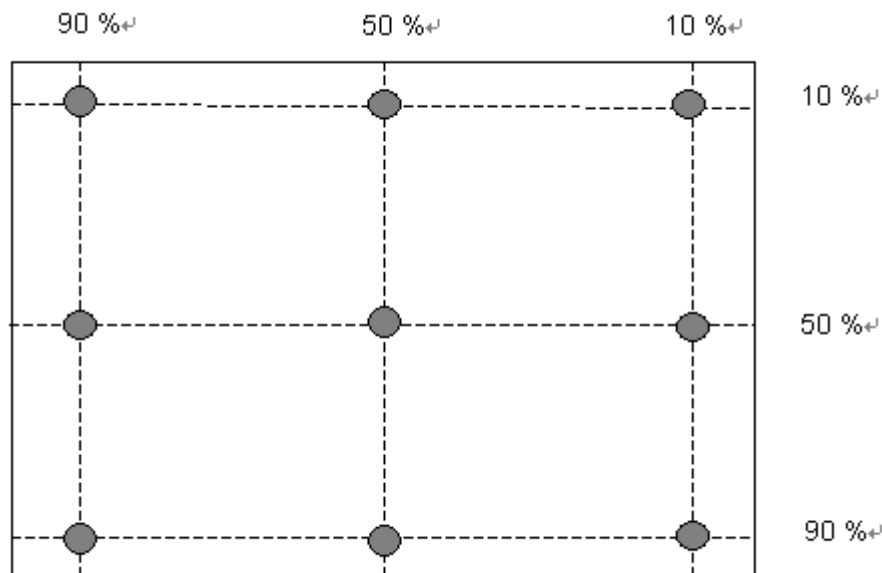

$$\text{Uniformity} = \frac{\text{Minimum Luminance in 9 points (1-9)}}{\text{Maximum Luminance in 9 Points (1-9)}}$$

**Note 8:** Crosstalk is defined as below and measured by TOPCON SR-3

$$CT = |YB - YA| / YA \times 100 (\%)$$

Where

YA = Luminance of measured location without gray level 0 pattern (cd/m<sup>2</sup>)

YB = Luminance of measured location with gray level 0 pattern (cd/m<sup>2</sup>)

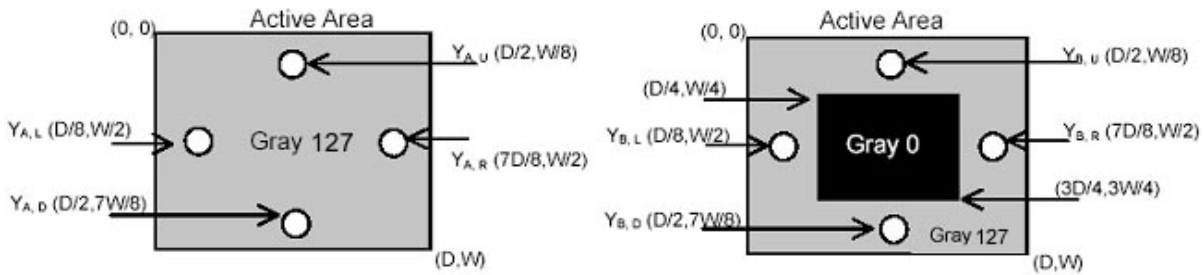

**Note 9:** Test Pattern: Subchecker Pattern measured by TOPCON SR-3

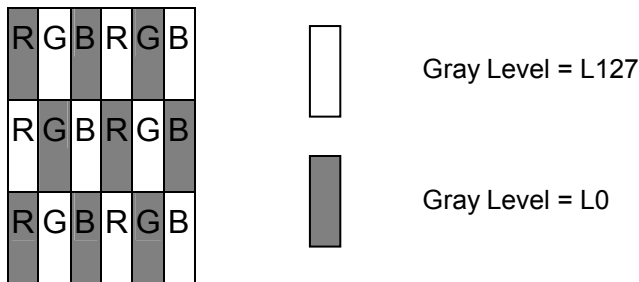

Method: Record dBV & DC value with TRD-100

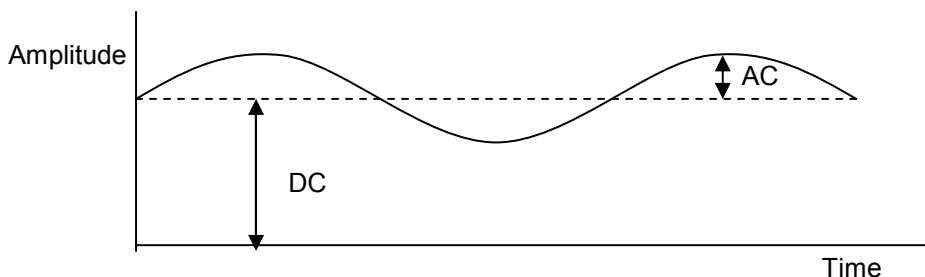

$$\text{Flicker (dB)} = 20 \log \frac{\text{AC Level (at 30 Hz)}}{\text{DC Level}}$$

### 3.0 Functional Block Diagram

The following diagram shows the functional block of the 18.5 inch Color TFT-LCD Module:

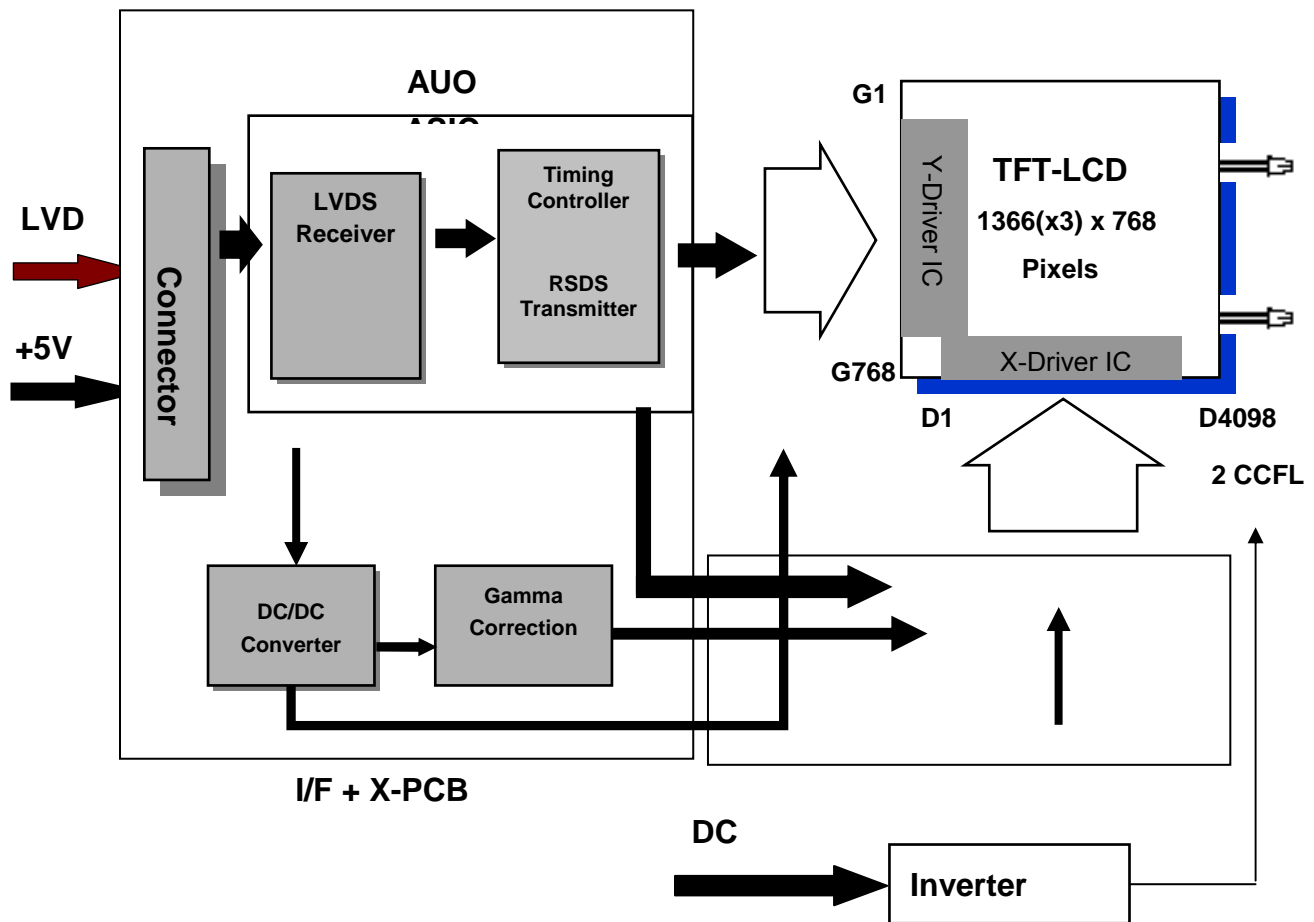

#### I/F PCB Interface:

FI-XB30SSRL-HF16(JAE)/MSCKT2407P30HB(信盛)

#### Mating Type:

FI-X30HL (JAE)(Locked Type)

## 4.0 Absolute Maximum Ratings

Absolute maximum ratings of the module are as following:

### 4.1 TFT LCD Module

Item	Symbol	Min	Max	Unit	Conditions
Logic/LCD Drive Voltage	VDD	4.5	+5.5	[Volt]	<b>Note 1,2</b>

### 4.2 Backlight Unit

Item	Symbol	Min	Max	Unit	Conditions
CCFL Current	ICFL	3.0	8	[mA] rms	<b>Note 1,2</b>

### 4.3 Absolute Ratings of Environment

Item	Symbol	Min.	Max.	Unit	Conditions
Operating Temperature	TOP	0	+50	[°C]	<b>Note 3</b>
Operation Humidity	HOP	5	90	[%RH]	
Storage Temperature	TST	-20	+60	[°C]	
Storage Humidity	HST	5	90	[%RH]	

**Note 1:** With in Ta (25 )

**Note 2:** Permanent damage to the device may occur if exceeding maximum values

**Note 3:** For quality performance, please refer to AUO IIS(Incoming Inspection Standard).

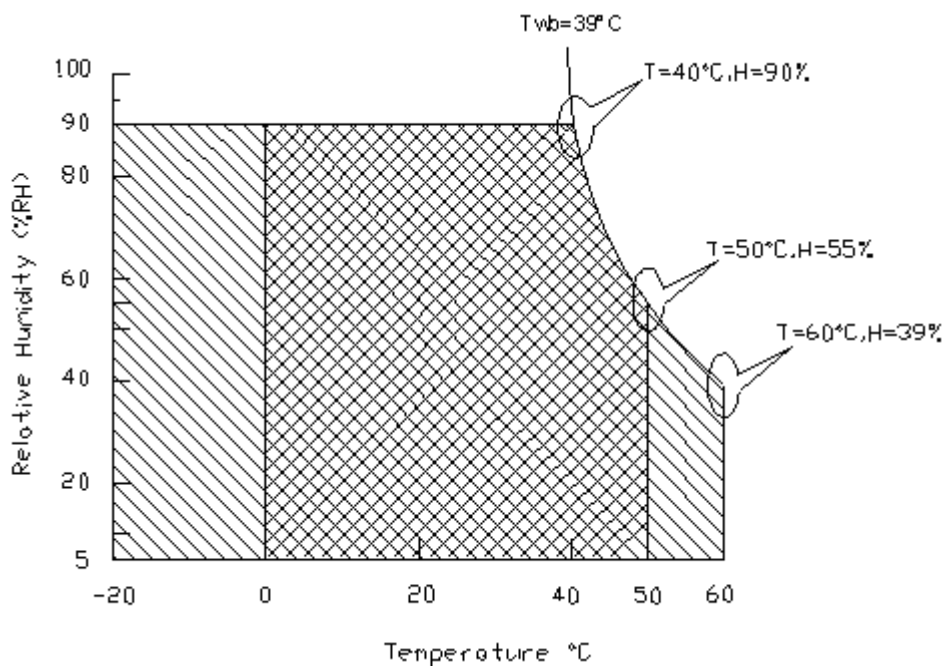

Operating Range



Storage Range

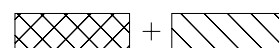

## 5.0 Electrical characteristics

### 5.1 TFT LCD Module

#### 5.1.1 Power Specification

Input power specifications are as following:

Symbol	Parameter	Min	Typ	Max	Unit	Conditions
VDD	Logic/LCD Drive Voltage	4.5	5.0	5.5	[Volt]	+/-10%
IDD	Input Current	-	0.6	0.7	[A]	VDD= 5.0V, All Black Pattern At 60Hz,
PDD		-	3	3.85	[Watt]	VDD= 5.0V, All Black Pattern At 60Hz
IRush	Inrush Current	-	-	3	[A]	Note 1
VDDrp	Allowable Logic/LCD Drive Ripple Voltage	-	-	200	[mV] p-p	VDD= 5.0V, All Black Pattern At 60Hz

**Note 1:** Measurement conditions:

The duration of rising time of power input is 470us.

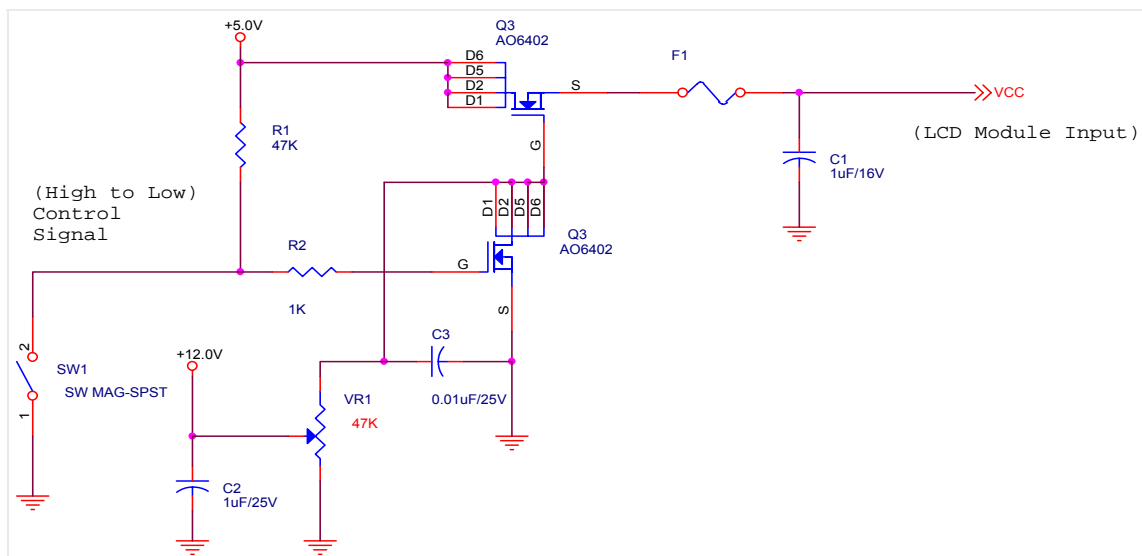

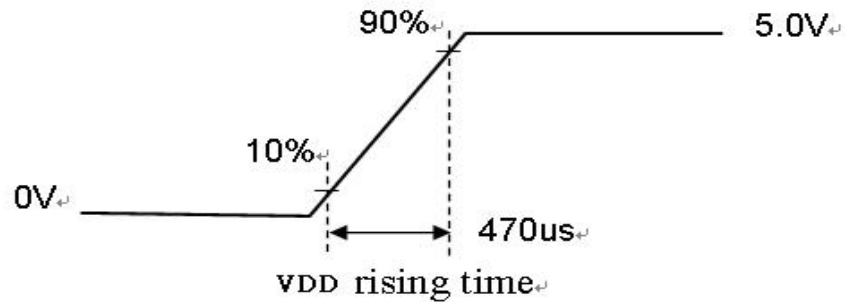

## 5.1.2 Signal Electrical Characteristics

Input signals shall be low or Hi-Z state when VDD is off. Please refer to specifications of SN75LVDS82DGG (Texas Instruments) in detail.

Characteristics of each signal are as following:

Symbol	Parameter	Min	Typ	Max	Units	Condition
VTH	Differential Input High Threshold	-	+50	+100	[mV]	VICM = 1.2V <b>Note 1</b>
VTL	Differential Input Low Threshold	-100	-50	-	[mV]	VICM = 1.2V <b>Note 1</b>
VID	Input Differential Voltage	100	400	600	[mV]	<b>Note 1</b>
VICM	Differential Input Common Mode Voltage	+1.0	+1.2	+1.4	[V]	VTH-VTL = 200mV (max) <b>Note 1</b>

### Note 1: LVDS Signal Waveform

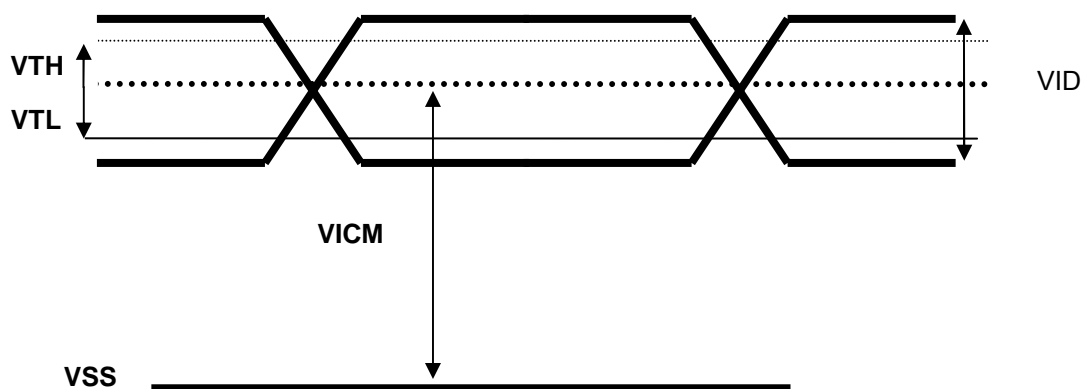

## 5.2 Backlight Unit

Parameter guideline for CCFL Inverter is under stable conditions at 25 (Room Temperature):

Parameter	Min.	Typ.	Max.	Unit	Note
CCFL Standard Current (ISCFL)	7.0	7.5	8.0	[mA] rms	
CCFL Operation Current (IRCFL)	3.0	7.5	8.0	[mA] rms	<b>2</b>
CCFL Frequency (FCFL)	40	50	80	[KHz]	<b>3, 4</b>
CCFL Ignition Voltage (ViCFL, Ta= 0 )	1650	-	-	[Volt] rms	<b>5</b>
CCFL Ignition Voltage (ViCF, Ta= 25 )	1250	-	-	[Volt] rms	
CCFL Operation Voltage (VCFL)	-	700 (@7.5mA)	880	[Volt] rms	<b>6</b>
CCFL Power Consumption (PCFL)	-	11	12.1	[Watt]	
CCFL Life Time (LTCFL)	40,000	50,000	-	[Hour]	<b>7</b>

**Note 1:** Typ. values are AUO recommended design values.

\*1 All of characteristics listed are measured under the condition using the AUO test inverter.

\*2 It is recommended to check the inverter carefully. Sometimes, interfering noise stripes appear on the screen, and substandard luminance or flicker at low power may happen.

\*3 While designing an inverter, it is suggested to check safety circuit very carefully. Impedance of CCFL, for instance, becomes more than 1 [M ohm] when CCFL is damaged.

\*4 Generally, CCFL has certain delay time after applying kick-off voltage. It is recommended to keep on applying kick-off voltage for 1 [Sec] until discharge.

\*5 Reducing CCFL current will increase CCFL discharge voltage and generally increases CCFL discharge frequency. So all the parameters of the inverter should be carefully designed so the inverter will not produce too much leakage current from high-voltage output.

\*6 For designing CCFL current, it is highly recommended to use symmetric and consistent sinusoidal wave for each CCFL input current with asymmetric ration of 10% or less in both positive area and negative area (ie.  $0.9 \cdot \sqrt{2} \cdot I_{rms} < I_1$  &  $I_2 < 1.1 \cdot \sqrt{2} \cdot I_{rms}$ ) as refer to the following diagram, otherwise proper CCFL functionality cannot be guaranteed.

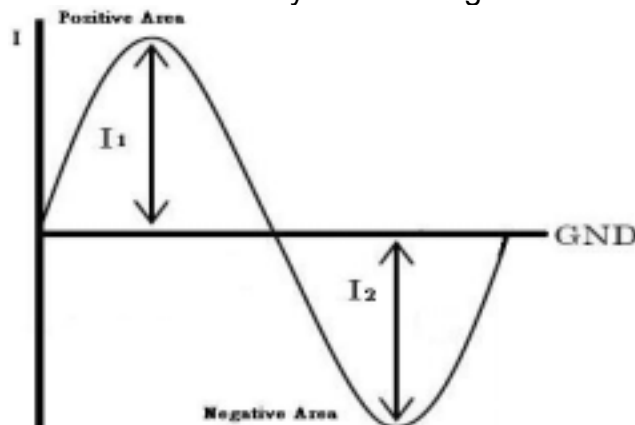



**Note 2:** CCFL standard current is measured by continue mode inverter at  $25\pm 2$  .

**Note 3:** CCFL discharge frequency should be carefully determined to avoid interference between inverter and TFT LCD.

**Note 4:** The frequency range will not affect lamp life and reliability characteristics.

**Note 5:** CCFL inverter should be able to release power that has generating capacity exceeding 1650 volt. Lamp units need minimum voltage, 1650 Volt, for ignition.

**Note 6:** The variance of CCFL power consumption is  $\pm 10\%$ . ( $IRCFL \times VCFL \times 2 = PCFL$ )

**Note 7:** Definition of life time: brightness becomes 50%. The minimum life time of CCFL unit is on the condition of 7.5mA CCFL current and  $25\pm 2$  .



## 6.0 Signal Characteristic

### 6.1 Pixel Format Image

Following figure shows the relationship of the input signals and LCD pixel format.

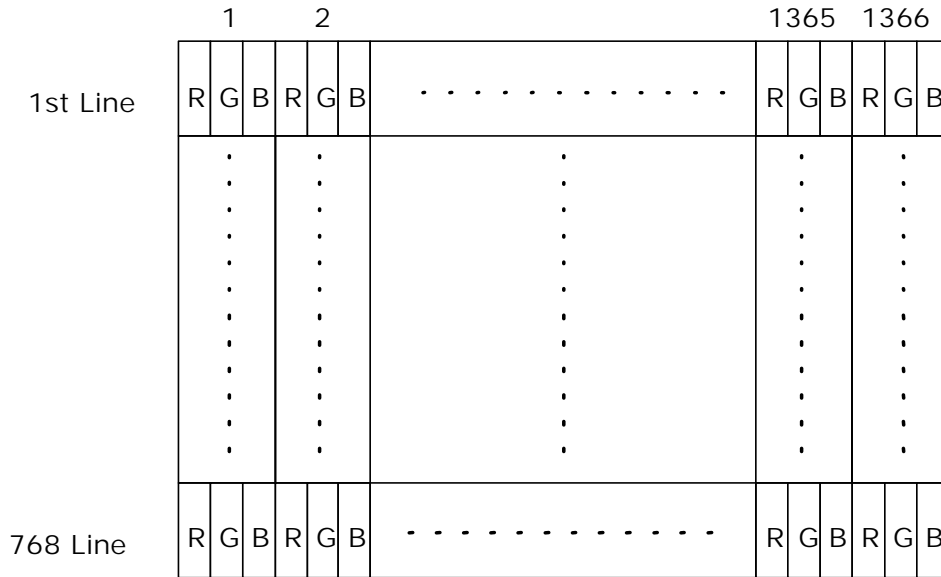

## 6.2 The input data format

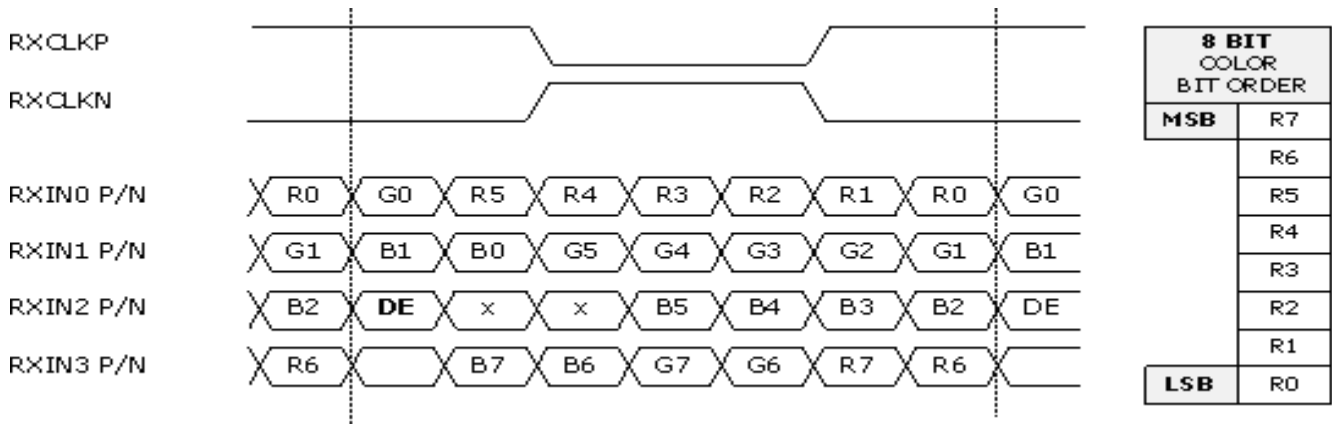

LVDS Data Mapping of NS Format

Note1: Normally, DE, VS, HS on EVEN channel are not used.

Note2: 8-bits signal input.

## 6.3 Signal Description

The module using one LVDS receiver SN75LVDS82(Texas Instruments). LVDS is a differential signal technology for LCD interface and high speed data transfer device. LVDS transmitters shall be SN75LVDS83(negative edge sampling). The first LVDS port(RxOxxx) transmits odd pixels while the second LVDS port(RxExxx) transmits even pixels.

PIN #	SIGNAL NAME	DESCRIPTION
1	NC	No contact (For AUO internal use)
2	NC	No contact (For AUO internal use)
3	NC	No contact (For AUO internal use)
4	GND	Power Ground
5	RXIN0-	Negative LVDS differential data input (0)
6	RXIN0+	Positive LVDS differential data input (0)
7	GND	Power Ground
8	RXIN1-	Negative LVDS differential data input (1)
9	RXIN1+	Positive LVDS differential data input (1)
10	GND	Power Ground
11	RXIN2-	Negative LVDS differential data input (2)
12	RXIN2+	Positive LVDS differential data input (2)
13	GND	Power Ground
14	RXCLKIN-	Negative LVDS differential clock input (clock)
15	RXCLKIN+	Positive LVDS differential data input (clock)
16	GND	Power Ground
17	RXIN3-	Negative LVDS differential data input (3)
18	RXIN3+	Positive LVDS differential data input (3)
19	GND	Power Ground
20	NC	No contact (For AUO internal use)
21	NC	No contact (For AUO internal use)
22	NC	No contact (For AUO internal use)
23	GND	Power Ground
24	GND	Power Ground
25	GND	Power Ground
26	VCC	+5V power supply
27	VCC	+5V power supply
28	VCC	+5V power supply
29	VCC	+5V power supply
30	VCC	+5V power supply

**Note1:** Start from left side

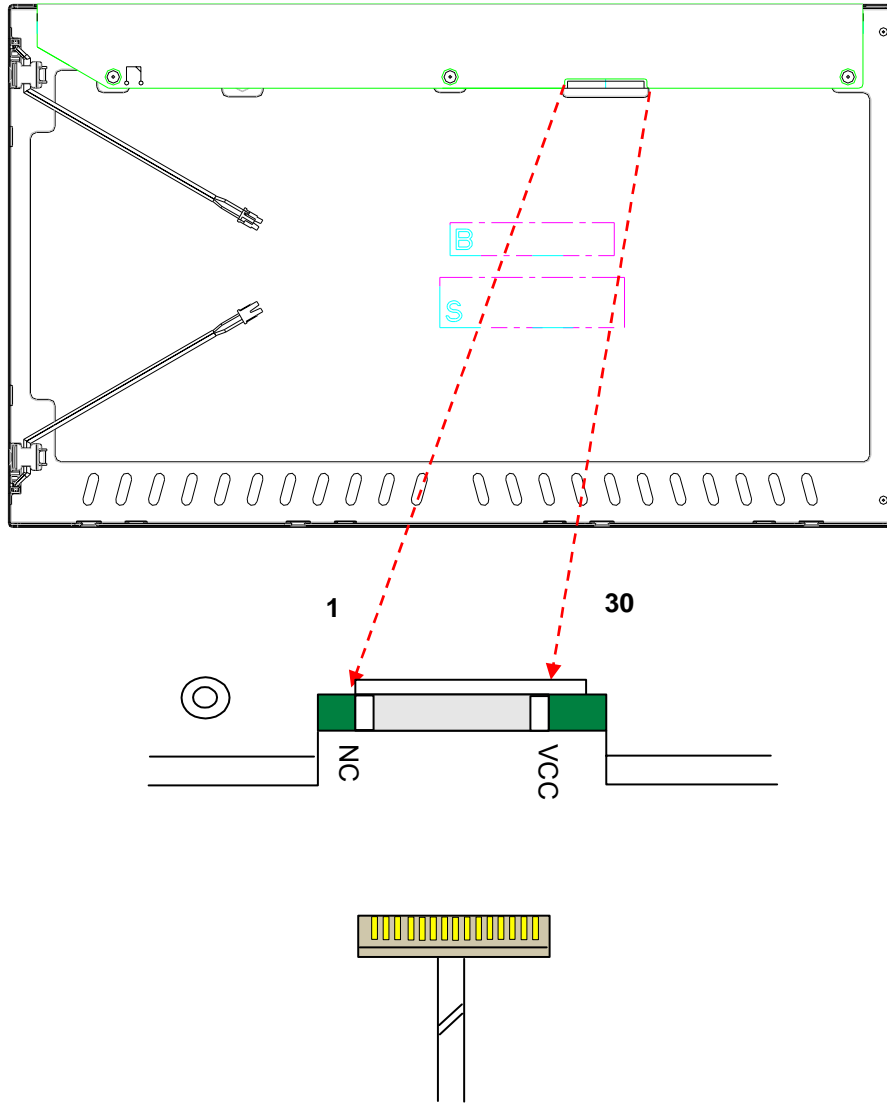

*Note2:* Input signals of clock shall be the same timing.

*Note3:* Please follow TV VESA Pin Assignment.

## 6.4 Timing Characteristics

Basically, interface timing described here is not actual input timing of LCD module but close to output timing of SN75LVDS82DGG (Texas Instruments) or equivalent.

Signal	Item	Symbol	Min	Typ	Max	Unit
V-section	Period	Tv	776	808	1023	Th
	Active	Tdisp(v)	768	768	768	Th
	Blanking	Tblk(v)	8	40	255	Th
H-section	Period	Th	1416	1606	2047	Tclk
	Active	Tdisp(h)	1366	1366	1366	Tclk
	Blanking	Tblk(h)	50	240	681	Tclk
Clock	Period	Tclk	-	12.8	-	ns
	Frequency	Freq	-	78	90	MHz
Frame Rate	Frame Rate	F	50	60	75	Hz

**Note1** : DE mode only

**Note2** : Clock Frequency 90MHz(Max.)= 1416(H)\*847(V)\*75Hz

## 6.5 Timing diagram

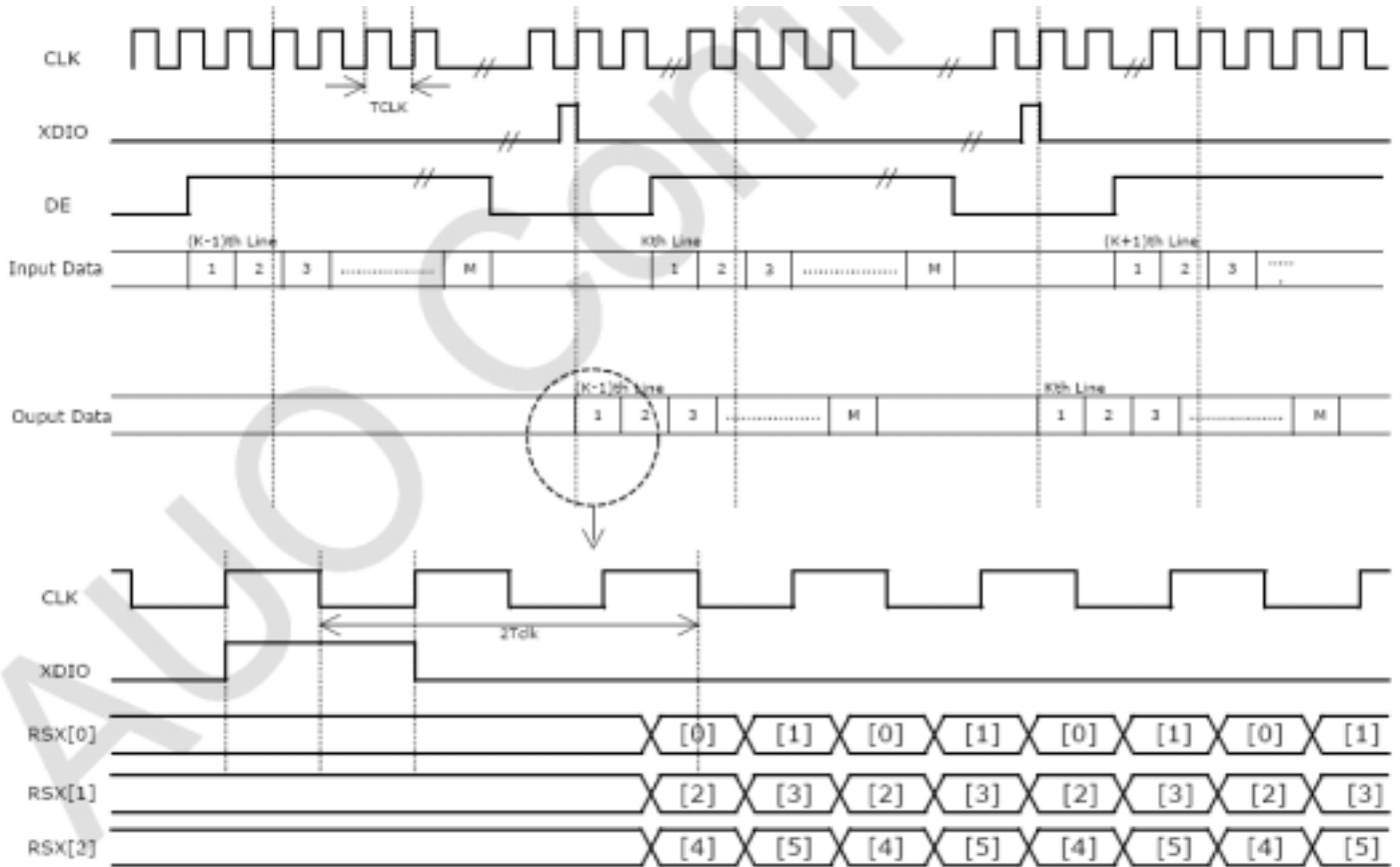

## 6.6 Power ON/OFF Sequence

VDD power and lamp on/off sequence are as follows. Interface signals are also shown in the chart. Signals from any system shall be Hi-Z state or low level when VDD is off.

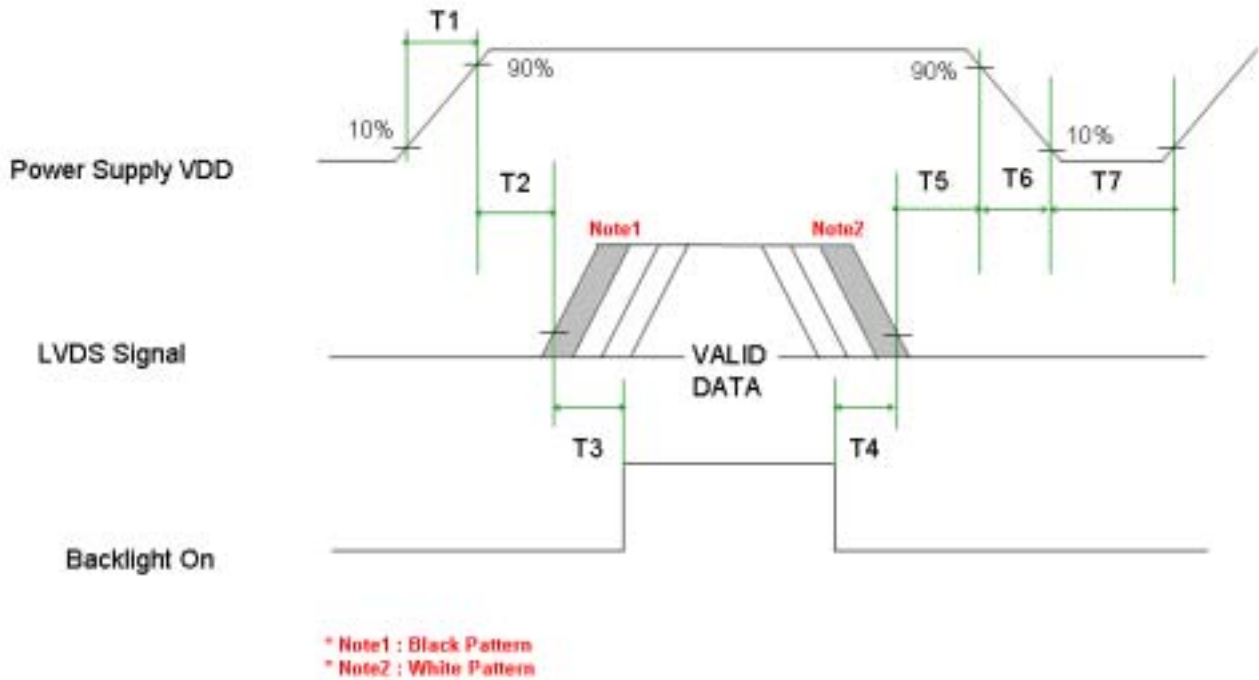

Parameter	Value			Unit
	Min.	Typ.	Max.	
T1	0.5	-	10	[msec]
T2	0	40	50	[msec]
T3	200	-	-	[msec]
T4	200	-	-	[msec]
T5	0.5	16	50	[msec]
T6	-	-	100	[msec]
T7	1000	-	-	[msec]

## 7.0 Connector & Pin Assignment

Physical interface is described as for the connector on module. These connectors are capable of accommodating the following signals and will be following components.

### 7.1 TFT LCD Module

Connector Name / Designation	Interface Connector / Interface card
Manufacturer	JAE or STM
Type Part Number	FI-XB30SSRL-HF16(JAE)/MSCKT2407P30HB(STM)
Mating Housing Part Number	FI-X30HL(JAE) (Locked Type) FI-X30H (JAE)(Unlocked Type)

#### 7.1.1 Pin Assignment

Pin#	Signal Name	Pin#	Signal Name
1	NC	2	NC
3	NC	4	GND
5	RXIN0-	6	RXIN0+
7	GND	8	RXIN1-
9	RXIN1+	10	GND
11	RXIN2-	12	RXIN2+
13	GND	14	RXCLKIN-
15	RXCLKIN+	16	GND
17	RXIN3-	18	RXIN3+
19	GND	20	NC
21	NC	22	NC
23	GND	24	GND
25	GND	26	VCC
27	VCC	28	VCC
29	VCC	30	VCC



## 7.2 Backlight Unit

Physical interface is described as for the connector on module. These connectors are capable of accommodating the following signals and will be following components.

Connector Name / Designation	Lamp Connector / Backlight lamp
Manufacturer	YEON HO
Type Part Number	35001HS-02L
Mating Type Part Number	35001WR-02LP

### 7.2.1 Signal for Lamp connector

	Connector No.	Pin No.	Input	Color	Function
Upper	CN1	1	Hot1	Pink	High Voltage (Lamp1)
		2	Cold1	White	Low Voltage(Lamp1)

	Connector No.	Pin No.	Input	Color	Function
Lower	CN2	1	Hot1	Pink	High Voltage(Lamp2)
		2	Cold1	White	Low Voltage (Lamp2)

## 8.0 Reliability Test

Environment test conditions are listed as following table.

Items	Required Condition	Note
Temperature Humidity Bias (THB)	Ta= 50 , 80%RH, 300hours	
High Temperature Operation (HTO)	Ta= 50 , 50%RH, 300hours	
Low Temperature Operation (LTO)	Ta= 0 , 300hours	
High Temperature Storage (HTS)	Ta= 60 , 300hours	
Low Temperature Storage (LTS)	Ta= -20 , 300hours	
Vibration Test (Non-operation)	Acceleration: 1.5 Grms Wave: Random Frequency: 10 - 200 Hz Sweep: 30 Minutes each Axis (X, Y, Z)	
Shock Test (Non-operation)	Acceleration: 50 G Wave: Half-sine Active Time: 20 ms Direction: ±X, ±Y, ±Z (one time for each Axis)	
Drop Test	Height: 60 cm, package test	
Thermal Shock Test (TST)	-20 /30min, 60 /30min, 100 cycles	<b>1</b>
On/Off Test	On/10sec, Off/10sec, 30,000 cycles	
ESD (Electro Static Discharge)	Contact Discharge: ± 8KV, 150pF(330Ω ) 1sec, 8 points, 25 times/ point.	<b>2</b>
	Air Discharge: ± 15KV, 150pF(330Ω ) 1sec 8 points, 25 times/ point.	
Altitude Test	Operation:10,000 ft Non-Operation:30,000 ft	

**Note 1:** The TFT-LCD module will not sustain damage after being subjected to 100 cycles of rapid temperature change. A cycle of rapid temperature change consists of varying the temperature from -20 to 60 , and back again. Power is not applied during the test. After temperature cycling, the unit is placed in normal room ambient for at least 4 hours before power on.

**Note 2:** EN61000-4-2, ESD class B: Certain performance degradation allowed. No data lost.  
Self-recoverable. No hardware failures.

## 9.0 Shipping Label

The label is on the panel as shown below:

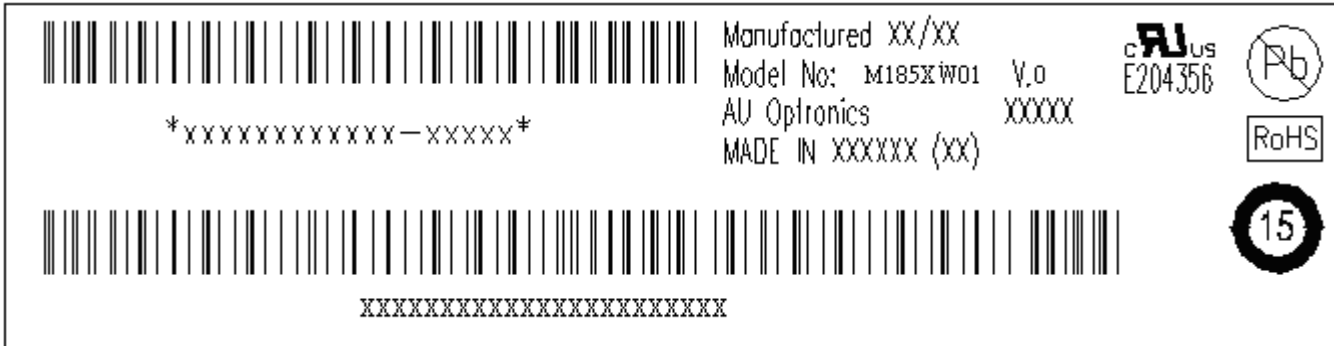

**Note 1:** For Pb Free products, AUO will add  for identification.

**Note 2:** For RoHS compatible products, AUO will add  for identification.

**Note 3:** For China RoHS compatible products, AUO will add  for identification.

**Note 4:** The Green Mark will be presented only when the green documents have been ready by AUO Internal Green Team.

# 10.0 Mechanical Characteristics

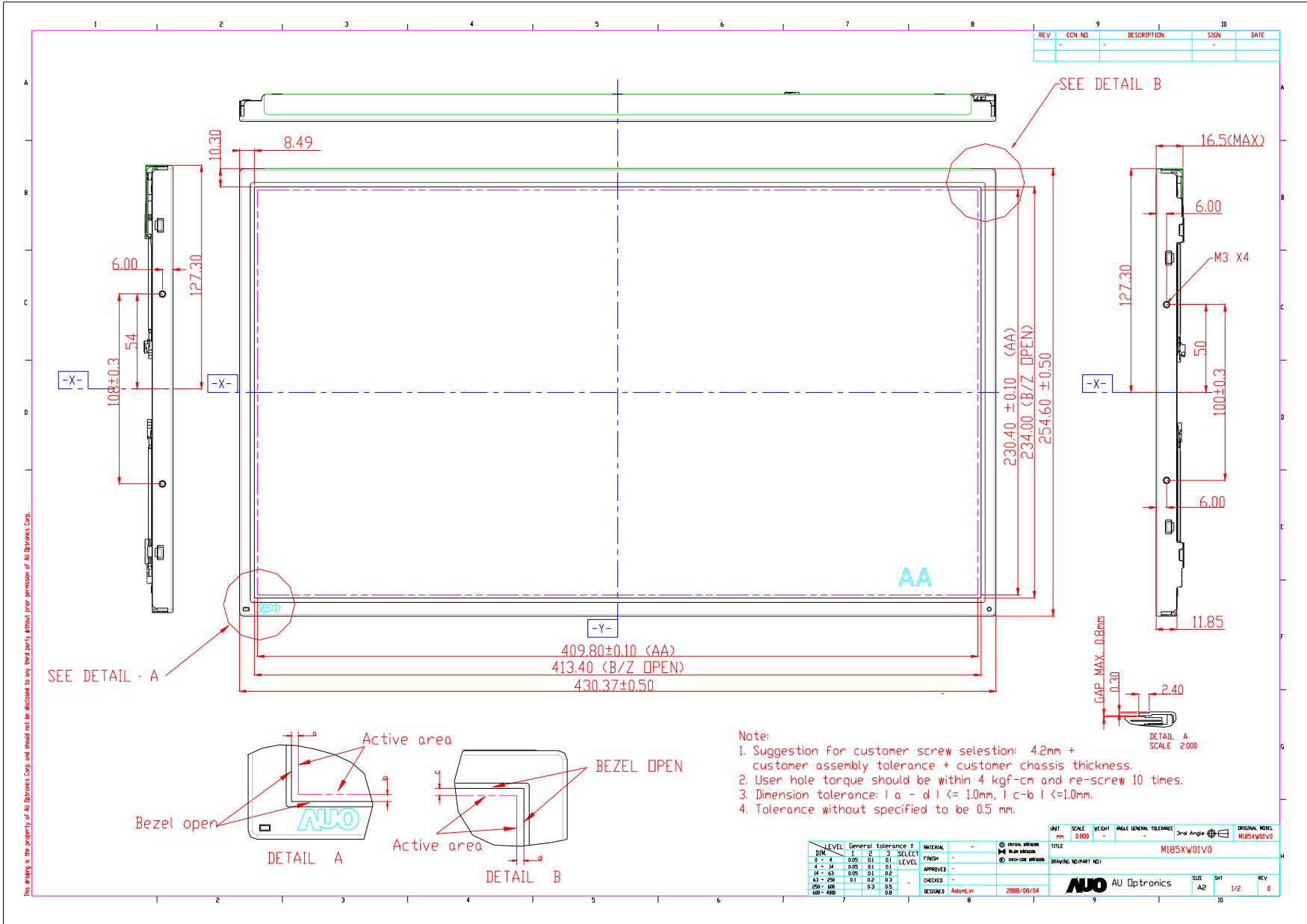

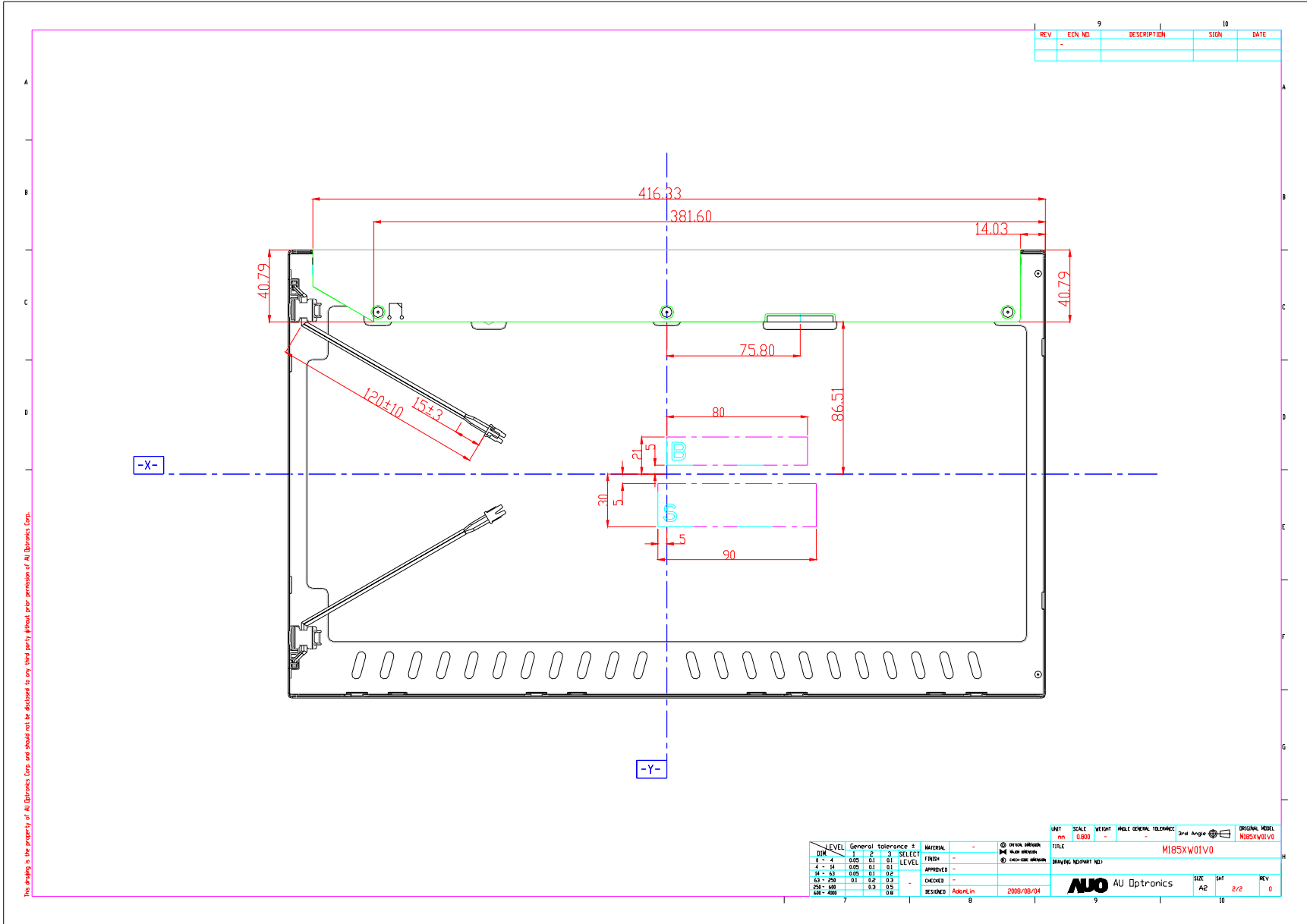

REV	ECON NO	DESCRIPTION	SIGN	DATE
-	-	-	-	-

This drawing is the property of AU Optronics Corp. and should not be disclosed to any third party without prior permission of AU Optronics Corp.

UNIT	SCALE	WEIGHT	MISC	GENERAL TOLERANCE	2nd Angle	ORIGINAL MODEL
mm	1:1	0.000	-	-	30°	M185XW01V0

DIN	LEVEL	General tolerance 1	2	3	SELECT	MATERIAL	OTHER DIMENSION	TITLE
1 - 4	0.05	0.1	0.1	LEVEL	FINISH	-	<input type="checkbox"/> DIM ALIAS <input type="checkbox"/> DIM ALIAS	M185XW01V0
4 - 14	0.05	0.1	0.1	LEVEL	APPROVED	-	<input type="checkbox"/> DIM ALIAS <input type="checkbox"/> CHECK-DATE	DRAWING NO/PART NO
14 - 63	0.05	0.1	0.2	-	CHECKED	-	-	-
63 - 250	0.1	0.2	0.3	-	DESIGNED	AdonLin	2008/08/04	AU Optronics SIZE SHF REV A2 2/2 0
250 - 400	0.2	0.3	0.5	-	-	-	-	-
400 - 600	0.3	0.5	0.8	-	-	-	-	-